



# ecoLine-b

high performance-cost effective  
below ground oil water separation



**Water Treatment for the World**

200 S Biscayne Blvd, Suite 4310, Miami, Florida 33131, USA  
Phone.: +1 (305) 372-1104 Fax: +1 (305) 328-9312  
e-mail [info@freytech.com](mailto:info@freytech.com), <http://www.freytech.com>

**FREYTECH** INC.

# Today's environmental legislation is hard enough to comply with.

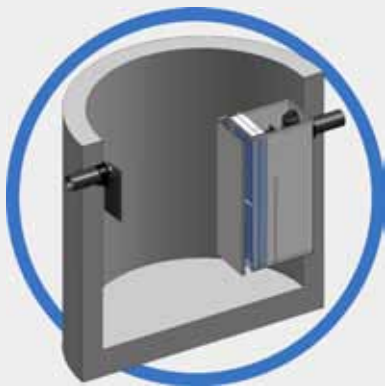

## **ecoLine-b meets tomorrow's standards today.**

It's not just the ecoLine's long maintenance intervals and low waste-disposal costs that make it such a good investment, but the fact that it is designed with future standards in mind. The ecoLine-b far exceeds the strict European standards (EN858) for performance (less than 5ppm of free oil) and far surpasses US requirements. The outstanding independent testing certificates demonstrate that ecoLine-b will provide clean water that exceeds today's environmental standards. ecoLine-b also allows for tighter, future environmental discharge compliance guidelines to be met with little or no modification to the system.

## **Stop throwing your money down the black hole of conventional oil/water separators. Put it where you can access it!**

All basic elements of the ecoLine-b system can be accessed from ground level. This minimizes confined entry requirements for routine cleaning and maintenance. Annual maintenance cost savings range from 30% to 50% lower than those of conventional separator systems. All internal stainless steel components can be factory installed in a standard precast concrete structure, which accelerates the installation of the ecoLine-b Oil/Water Separator. This provides the first substantial cost savings in the form of reduced construction site labor. **The ecoLine-b components can be designed in a modular way, which means these units can be installed into existing concrete tanks, even if the manholes are very small.**



## **Working Principle.**

The ecoLine-b oil/water separator is designed to separate non-emulsified light liquids or low-water-soluble fluids with a specific gravity below 0.95 (gasoline, diesel, heating oils and other mineral oils) from effluent discharge. A two-step separation process, gravity separation and removal of small oil particles by coalescing media elements, produces high removal efficiencies.

### *Purification Step 1: Gravity Separation*

The optional upstream grit chamber removes solids from the influent, thus ensuring unimpeded functioning of the oil separator itself. The grit trap is the first concrete tank of a standard two-tank design. The grit chamber also compensates for influent temperature fluctuations, influent oil concentration influxes and initializes the separation of light fluids.

### *Purification Step 2: Enhanced Coalescing Media*

In the residual oil media, fine droplets that are too small to be separated by gravity alone are accumulated into bigger drops that rise to the surface. This enhanced coalescing media is made of durable reticular (i.e. "net-like") soft polyurethane foam. The media-cartridge is very easy to lift out and reinstall once it is cleaned/rinsed with a garden hose. The outlet structure features a venting pipe that provides an effluent sampling port. The separated water that leaves the ecoLine-b has a residual contamination of free petroleum content of less than 5 mg/liter.

### *Spill Control:*

The automatic shut-off valve closes the outlet pipe when the maximum oil storage capacity is reached.



# ecoLine-b model sizes.

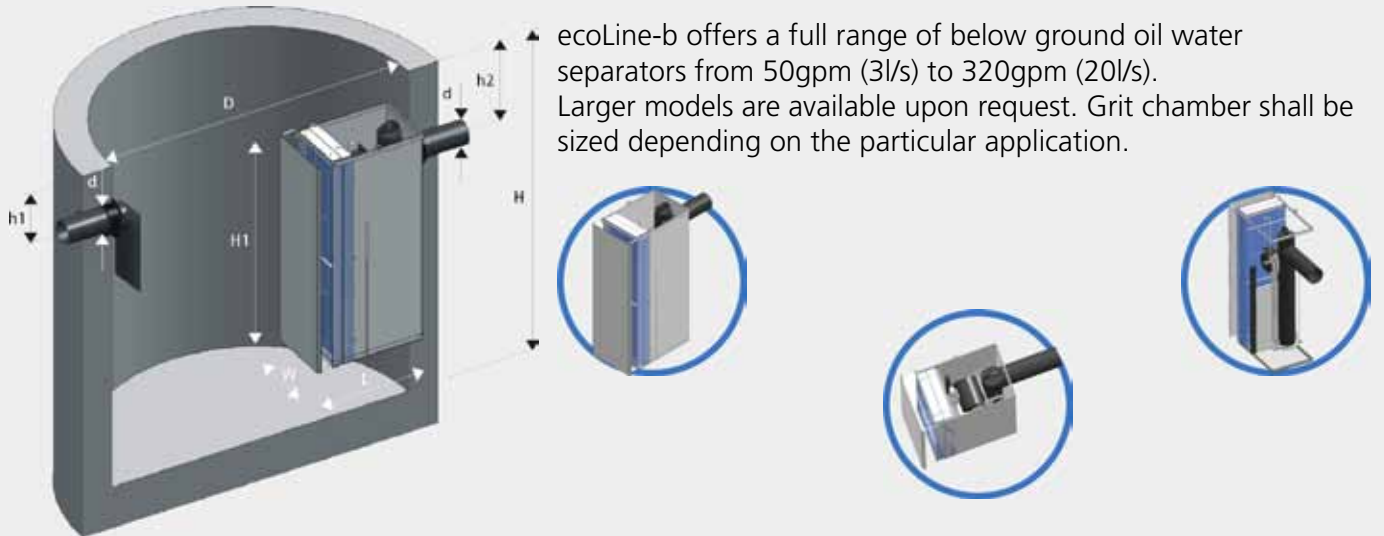

ecoLine-b offers a full range of below ground oil water separators from 50gpm (3l/s) to 320gpm (20l/s). Larger models are available upon request. Grit chamber shall be sized depending on the particular application.

Item no.	Item	Flow rate		D*		H*		h1		h2		d		H1		W		L		Weight	
		[l/s]	[gpm]	[mm]	[ft]	[mm]	[in]	[mm]	[in]	[mm]	[in]	[mm]	[in]	[mm]	[in]	[mm]	[in]	[mm]	[in]	[kg]	[lb]
101872	ecoLine-b NS03	3,0	50	1200	4	1500	59	225	9	275	11	100	4	1000	39	300	12	520	20	26,5	59
101874	ecoLine-b NS10	10,0	160	2000	6	2000	79	250	10	300	12	150	6	1000	39	450	18	670	26	38,5	85
101876	ecoLine-b NS20	20,0	320	2500	8	2000	79	320	13	370	15	200	8	1100	43	450	18	930	37	51	113
102016	ecoLine-b NS40	40,0	630	Available upon request. Sizing of grit chamber and separation chamber depending on application.				838	33	888	35	300	12	1250	49	905	35,5	760	30	91	201
102017	ecoLine-b NS50	50,0	790					838	33	888	35	300	12	1250	49	905	35,5	910	36	105	232
102018	ecoLine-b NS70	70,0	1100					838	33	888	35	300	12	1250	49	905	35,5	1360	53,5	120	265

# ecoLine-b Operation and Maintenance.

## Installation:

For installation guidelines, please refer to our installation manual. Install tank below the frost level.

## Maintenance:

The coalescing media cartridge has to be cleaned periodically. Since the maintenance intervals strongly depend on the particular application, check the condition of the filter element weekly during the first 60 days of operation. The filter media can be cleaned/rinsed with a garden hose. Recycle the wash-water to the separator. Do not expose the media to sunlight or UV-radiation for extended periods of time.

Remove sludge and oil from the system periodically.

For operating and maintenance details, please refer to our O&M manual.

## Temperature range of operation:

5°C to 60°C (41°F to 140°F) – up to 85°C (185°F) with intermittent flows

## Material:

Stainless Steel Grade 304 and high grade polyethylene

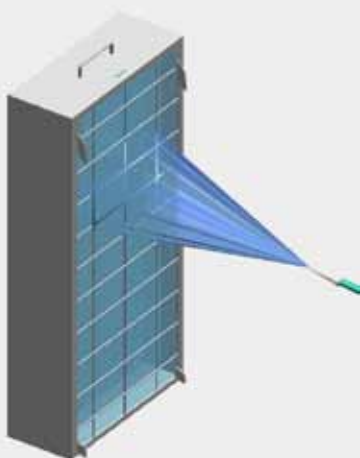

## ecoLine-b

### Automatic oil draw-off device.

As an option the ecoLine-a can be ordered with an automatic oil draw-off device. This built in ADD mechanically removes accumulated light liquids 24/7 from the water surface and stores them in an external oil recipient or oil drum. The collected oil is free of any water (99.7% pure).

For further information about the automatic oil draw-off, please see our O&M manual for the ADD HDPE.



#### **Water Treatment for the World**

200 S Biscayne Blvd, Suite 4310, Miami, Florida 33131, USA  
Phone.: +1 (305) 372-1104 Fax: +1 (305) 328-9312  
e-mail [info@freytech.com](mailto:info@freytech.com), <http://www.freytech.com>

**FREYTECH** INC.